

# Guinness

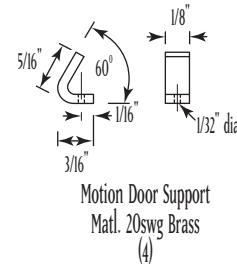

NB Please note the dimensions given for the Covers and Footplates are for guidance only and should be acquired on assembly.

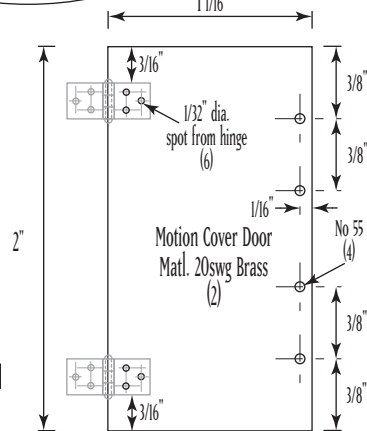
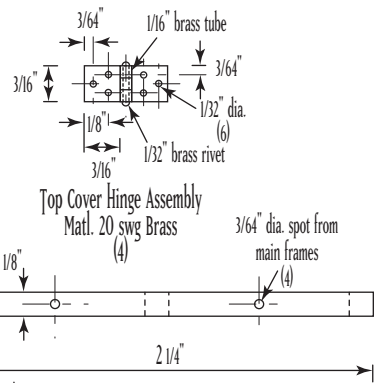
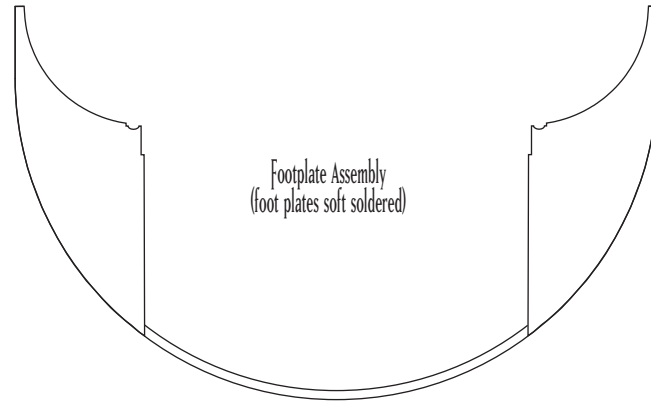
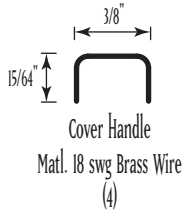
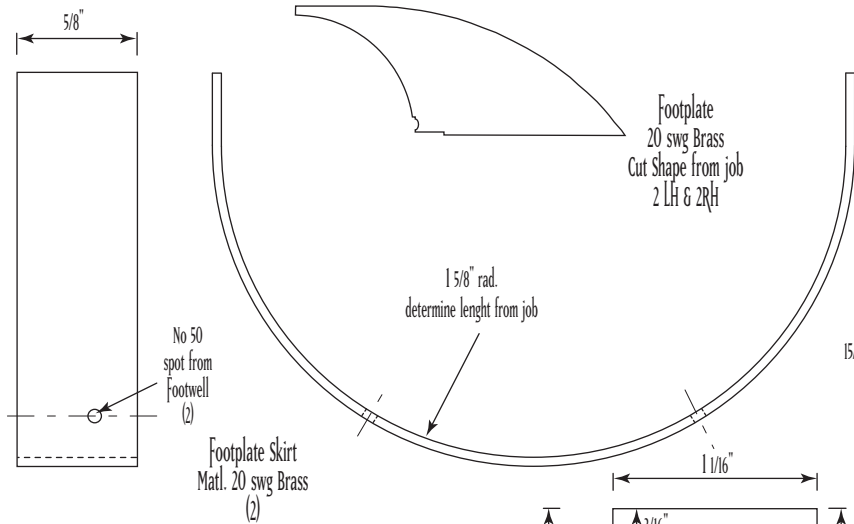
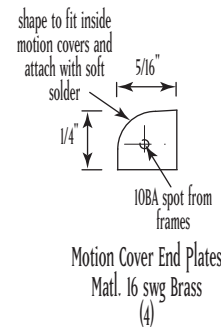
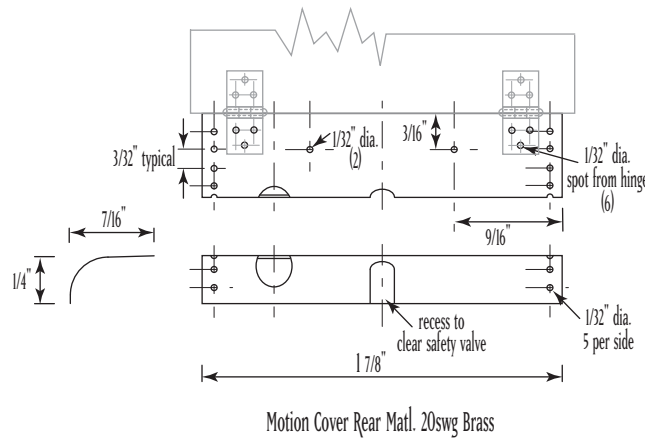
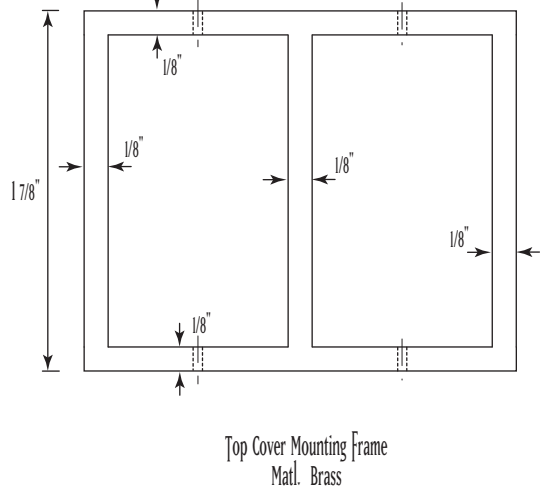
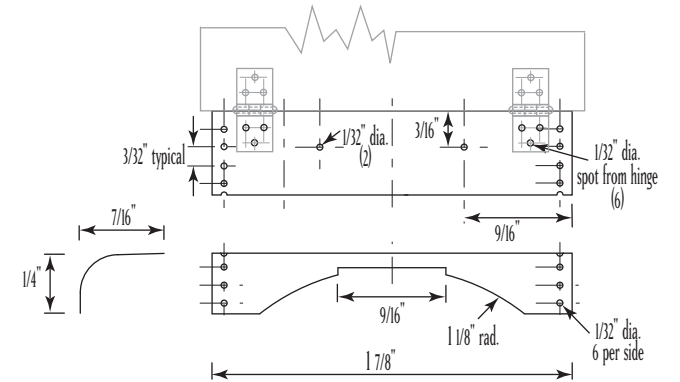

16 mm to 1 foot scale

Title:	Footplates & Top Covers
Date:	14/10/2009
Tolerance:	+ 0.005" - 0.005" Unless Stated Otherwise
Material:	As Stated
Drawn By:	Robert John Bath